

Data sheet

White top sheet
coilcoated

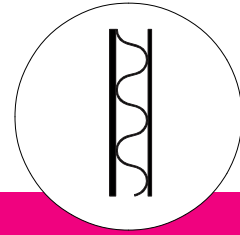

Panel type	Alu cc 08-02-05 hl / H6	
Top cover sheet		
Thickness of sheet	0.8 mm	(US: 0.032 in)
Surface	HDP RAL 9010 (white) ⁽¹⁾	
Alloy / Condition	EN AW-5754 H42	
Proof stress $R_{p0.2}$ [N/mm ²]	≥ 140	
Tensile stress R_m [N/mm ²]	≥ 220	
Back cover sheet		
Thickness of sheet	0.5 mm	(US: 0.020 in)
Surface	primered	
Alloy / Condition	EN AW-5182 H48	
Proof stress $R_{p0.2}$ [N/mm ²]	≥ 300	
Tensile stress R_m [N/mm ²]	≥ 330	
Dimensions		
Overall thickness [mm]*	6.0 ± 0.15	(US: 0.217 in ± 0.006 in)
Standard width [mm]*	1,500 -0/+6 ⁽⁴⁾	(US: 4.92 ft -0/+0.236 in) ⁽⁴⁾
Standard length [mm]*	3,000 -0/+6	(US: 9.84 ft -0/+0.236 in)
* other dimensions on request		
Mechanical and physical properties ⁽⁷⁾		
Weight [kg/m ²]	4.6	
Rigidity [Nmm ² /mm] ⁽²⁾ EI/b, longitudinal / transverse	700,000 / 625,000	
Bending moment [Nmm/mm] ⁽²⁾ Limit of elasticity M_{el} , longitudinal / transverse Max. bending moment M_{max} , longitudinal / transverse	≥ 550 / ≥ 500 ≥ 900 / ≥ 600	
Compressive strength [N/mm ²] ⁽³⁾	≥ 3.0	
Temperature stability ⁽⁶⁾	-40 to 100 °C (US: -40 to 212 °F)	
Approvals / Certificates	on request	

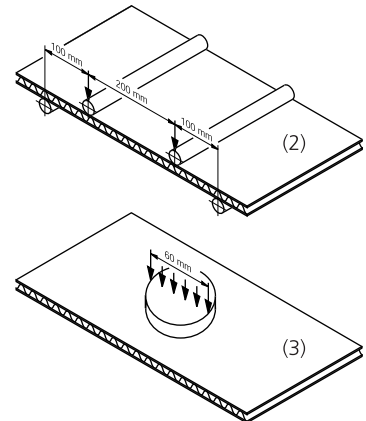

Alu cc 08-02-05 hl / H6

- (1) High Durable Polyester (HDP) coilcoated
Other colours and paint-systems on request
- (2) Bending test at room temperature following DIN 53293
Since the panel core is a corrugated sheet,
two different load cases have to be considered:
longitudinal: bending axis perpendicular to the corrugation
transverse: bending axis parallel to the corrugation
- (3) Pressure test at room temperature following DIN 53291
- (4) Border margin max. 5 mm (US: max. 0.197 in)
- (5) Cut by hammer shears
- (6) Others on request
- (7) Further characteristics can be supplied on demand

Protective film

If panels are supplied with a protective film, it must be taken off not later than 6 months after delivery. Bigger temperature changes and exposure to direct sunlight should be avoided since this may reduce the duration. Partial removal of the film, e.g. during processing, may lead to dirt marks along the borders.